

Press release

Neukirchen-Vluyn (Germany), 18 December 2020

RWTH Aachen University relies on cleaning technology from SCHWING Technologies

The Institute of Textile Technology (ITA) at RWTH Aachen University uses the compact thermal cleaning system VACUCLEAN COMPACT for its research in the field of thermoplastic high-performance fibers. The system safely removes thermoplastic polymers from machine parts such as spinnerets, nozzle housings, spinning pumps and screws

Development of innovative high-performance fibers and fiber-based products is the research focus of the Institute of Textile Technology (ITA) at the Department of Textile Mechanical Engineering at RWTH Aachen University. The team is led by Dr.-Ing. Pavan Kumar Manvi and Dr.-Ing. Franz Pursche, conducting research in the field of spinning technologies for multi- and monofilaments to develop innovative fibers. Their focus is on high-performance and sustainable fibers with new property profiles and broad application options. These include lightweight construction, mobility, health, construction and housing, energy and information as well as communication. Tests are carried out with all types of thermoplastic polymers. They range from commodity plastics to bio-based and recycled polymers. In the Institute's pilot plant, researchers use melt spinning equipment ranging from laboratory to pilot plant scale, employing screws, spinnerets complete with spinning housings and spinning pumps.

In order to ensure fast and reliable removal of thermoplastic polymers, a compact vacuum pyrolysis system from SCHWING Technologies has been available for tests of the spinning technology for several months. Within a few hours, the VACUCLEAN COMPACT removes all adhered polymer in only one operation. The fully automatic process cleans safely and gently at a maximum of 450 degrees Celsius with vacuum pyrolysis and oxidation. Loading capacity is a maximum of 50 kilograms of part weight. Cleaned machine parts can be returned to the test process after post-treating in an ultrasonic bath or by sandblasting.

ITA develops new fiber-based material systems

In order to produce new fiber-based material systems, the facilities in the pilot plant and test laboratory run on an industrial and laboratory scale. The institute conducts research to develop new fiber-based material systems using current and digitized machine technology. Focus areas range from functionalization, new materials, sustainability and recycling to process optimization and process upscaling. Tests are carried out from laboratory to industrial scale - including a current project from the healthcare sector on the subject of "highly cleanable bristles for toothbrushes". The team led by Dr. Franz Pursche, Head of Monofilament Technologies, is investigating how cleaning performance can be optimized using a special filament geometry. "Special nozzles are required to produce the filaments," explains Dr. Pursche. "They consist of complex channel geometries. In terms of cleaning, they require a modern and reliable pyrolysis unit."

Thermal vacuum pyrolysis unit cleans small machine parts

Machine parts used are changed or cleaned three times a week on average. When doing this, the first step is to allow the nozzle parts of the spinning systems to cool down, disassemble them and transport them to the pyrolysis unit. Around 10 to 25 kilograms of metal parts are serviced per cleaning cycle in the research project. Once the nozzle parts are properly positioned in the cleaning system, the door is closed, the program is selected and the fully automatic vacuum pyrolysis is started. Cleaning takes place in an electrically heated vacuum cleaning chamber, whose temperature is measured directly on the machine parts. First, the system heats up slowly and gently under vacuum. The actual pyrolysis process only starts at around 440 degrees Celsius. Any remaining carbon is removed by a subsequent oxidation phase at around 450 degrees Celsius. This all happens fully automatically, takes around five to six hours and leaves virtually no residue. To save time, the cleaning process at ITA usually runs overnight. Afterwards, the nozzle parts have to be allowed to cool, sandblasted, cleaned in an ultrasonic bath and finally inspected under a microscope.

Reliable cleaning secures project goals

Due to the high ITA plant utilization of almost 100 percent per year, the support work for spinning preparation must be carried out with a very high degree of reliability. This also includes nozzle cleaning. "In the worst case, a nozzle that is not cleaned leads to spinning breaks, putting not only trial days but entire weeks at risk," describes Peter Rüdiger, a member of the research team. Dr. Manvi, head of the Spinning Technology Center, adds that in other cases both filament formation and the associated filament properties are negatively affected. Therefore, the process-related influencing variables could only be investigated suboptimally. "In addition, the short cleaning period also supports us in starting new trials. This is particularly important with regard to the development of new nozzle geometries. For cleaning, we rely on the environmentally friendly and low-emission technology with clean exhaust gases without contamination for this purpose," concludes Dr. Manvi.

Compact system ideal for laboratory situation

The vacuum pyrolysis system weighs only around 750 kilograms and, at 100 x 125 x 245 cm (W x D x H), is only slightly larger than a spacious refrigerator. All essential components are integrated into the interior of the system to save space: these include a catalyst section, a vacuum pump, a control cabinet and fittings, as well as the 50 x 50 x 35 cm (W x D x H) cleaning chamber including loading platform. The system is conveniently controlled via a touchscreen HMI panel. Thanks to an external traffic light system, users can always keep an eye on the cleaning status, even from a distance. With the new, electrically operated and easy-to-install system, SCHWING engineering team responds to the internationally increased demand especially for more compact systems. In addition to the small-format system, SCHWING's vacuum pyrolysis technology is already used at several textile technology institutes. In addition to the Institute for Textile Technology at RWTH Aachen University, this includes the Institute for Textile Machinery and Textile High Performance Materials Technology at TU Dresden. Another SCHWING user is the European center CETI Centre Européen des Textiles Innovants located in Lille, France.

Further Information (VACUCLEAN CPMPACT): <https://www.thermal-cleaning.com/en/cleaning-systems-and-accessories/vacuum-pyrolysis-systems.html>

Keywords: Research, RWTH Aachen University, Institute of Textile Technology, ITA, VACUCLEAN COMPACT, vacuum pyrolysis system, thermal cleaning, polyester, polyamide, polyolefin, recycled polymer, plastic removal, machine part cleaning, spinnerets, screws, spinning pumps

About SCHWING Technologies

SCHWING Technologies has been operating for over 50 years and is the worldwide technological leader for high-temperature systems for thermal cleaning, thermo-chemical finishing and heat treatment of metal parts and tools. Managing directors are Ewald Schwing, Thomas Schwing and Alfred Schillert. The owner-managed company designs, manufactures, and operates systems at its headquarters in Neukirchen-Vluyn in Germany's Lower Rhine region. Built upon the achievements of German engineering, the medium-sized business is globally the best-known specialist in the removal of plastics. Among SCHWING's approximate 2,500 international clients are companies from the plastics and fiber industries, as well as from the chemicals and automobile sectors. For every cleaning need, the company with its approximately 80 employees offers the most economically, ecologically and qualitatively best technology and cleaning solution. SCHWING is also a reliable service partner for contract cleaning by processing more than 250,000 tools and parts each year to the highest environmental and qualitative standards. Founded in 1969, the company celebrates its 50th anniversary in 2019 and opened SCHWING Technologies North America Inc., a new sales company in the USA, in that year.

Press contact

Nicola Leffelsend
SCHWING Technologies GmbH
Oderstraße 7
47506 Neukirchen-Vluyn
M +49 173 9774780
T +49 2845 930 146
redaktion@schwing-tech.com
www.schwing-technologies.com

Facebook: schwing.technologies
Twitter: SCHWING_TECH
LinkedIn: SCHWING Technologies GmbH
YouTube: ThermalCleaning

About the Institute of Textile Technology (ITA) at RWTH Aachen University

The Institute of Textile Technology at RWTH Aachen University (ITA) is a university research and teaching facility and the core of the ITA Group, www.ita.rwth-aachen.de. The ITA Group sees itself as an internationally active research and training service provider with approximately 400 employees for fiber-based high-performance materials, textile semi-finished products and their manufacturing processes.

Press contact

Viola Siegl

Institut für Textiltechnik (ITA) der RWTH Aachen University

Otto-Blumenthal-Str. 1

52074 Aachen

T +49 241 80 234 21

Viola.Siegl@ita.rwth-aachen.de

www.ita.rwth-aachen.de

Facebook ITA: TextiltechnikAachen

Twitter ITA: ITA_RWTHAachen

LinkedIn ITA: Institut für Textiltechnik der RWTH Aachen University

YouTube ITA: Institut für Textiltechnik der RWTH Aachen

Photos

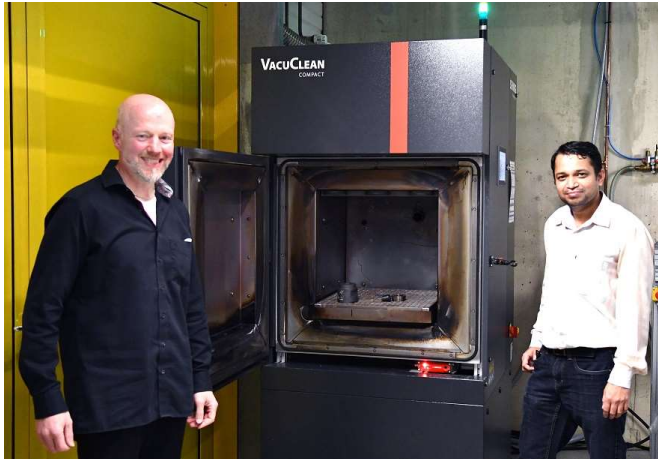

In the VACUCLEAN COMPACT vacuum pyrolysis system, Dr. Pavan Kumar Manvi (right) and his colleague Peter Rüdiger (left) have small machine parts cleaned on average three times a week

Picture credits: SCHWING Technologies

Download: https://drive.google.com/file/d/109ITi4JyqH0I4TOyoMMCBi0P0_9CZEnn/view?usp=sharing



To save time, the automatic cleaning process at the Institute of Textile Technology ITA usually runs overnight. Peter Rüdiger, member of the research team, shows the machine parts finally cleaned in the ultrasonic bath

Picture credits: SCHWING Technologies

Download: <https://drive.google.com/file/d/1QziMbZXJ-oeoA56qrNYC9L7nPbCxEcA6/view?usp=sharing>



Machine parts of the Institute of Textile Technology ITA before thermal cleaning

Picture credits: SCHWING Technologies

Download: <https://drive.google.com/file/d/1InViseBfgqEFKes4FjKbcV6WJFuSoB4f/view?usp=sharing>



Machine parts of the Institute of Textile Technology ITA after thermal cleaning

Picture credits: SCHWING Technologies

Download: <https://drive.google.com/file/d/1yUqhzeBEi7aS9pWn2jV1P-xHvmrSv-Ku/view?usp=sharing>



The compact and fully automatic vacuum pyrolysis system is particularly suitable for the thermal plastic removal of smaller molds up to a maximum loading capacity of 50 kilograms part weight. This includes small screws, spinnerets including spinning housings and spinning pumps

Picture credits: SCHWING Technologies

Download: <https://drive.google.com/file/d/18ih1z4JAbSk9lFK6E-CcjG0qEZj9oJ2e/view?usp=sharing>

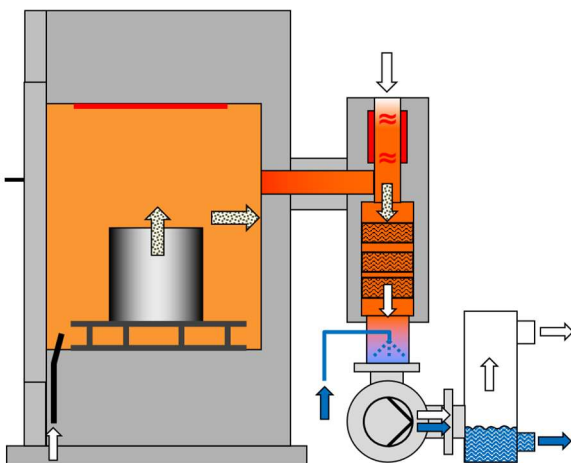

Operating principle of the compact and fully automatic vacuum pyrolysis system. The cleaning process takes about five to six hours and also removes thermal polymers safely and gently at a maximum of 450 degrees Celsius with vacuum pyrolysis and oxidation

Picture credits: SCHWING Technologies

Download: <https://drive.google.com/file/d/1HcM1CJod9xpP9rS2Auj3WE0EQS6xG1Zw/view?usp=sharing>